



Ludwig
uprion KG

Since 1838

Lagersortiment



Inhaltsverzeichnis

Hartmetallkreissägeblätter	2
Metallbandsägeblätter Bimetall	3
Rohrkreissägeblätter	4
blank für Orbitalum / +GF+ & AxxAir	4
Black Fire beschichtet für Orbitalum / +GF+ & AxxAir	4
Segmentkreissägeblätter	5
Vollstahlkreissägeblätter	6
HSS Vollstahlkreissägeblätter dampfbehandelt	6
HSS Vollstahlkreissägeblätter blank	8
HSS Vollstahlkreissägeblätter blank für Baiermaschinen	9
HSS Vollstahlkreissägeblätter dampfbehandelt für Rems Roller	9
HSS-E Vollstahlkreissägeblätter dampfbehandelt für Rems Roller	9
HSS-E Vollstahlkreissägeblätter dampfbehandelt	10



- Sonderausführungen realisieren wir gerne kurzfristig für Sie -

Hartmetallkreissägeblätter

für Jepson Dry Cutter

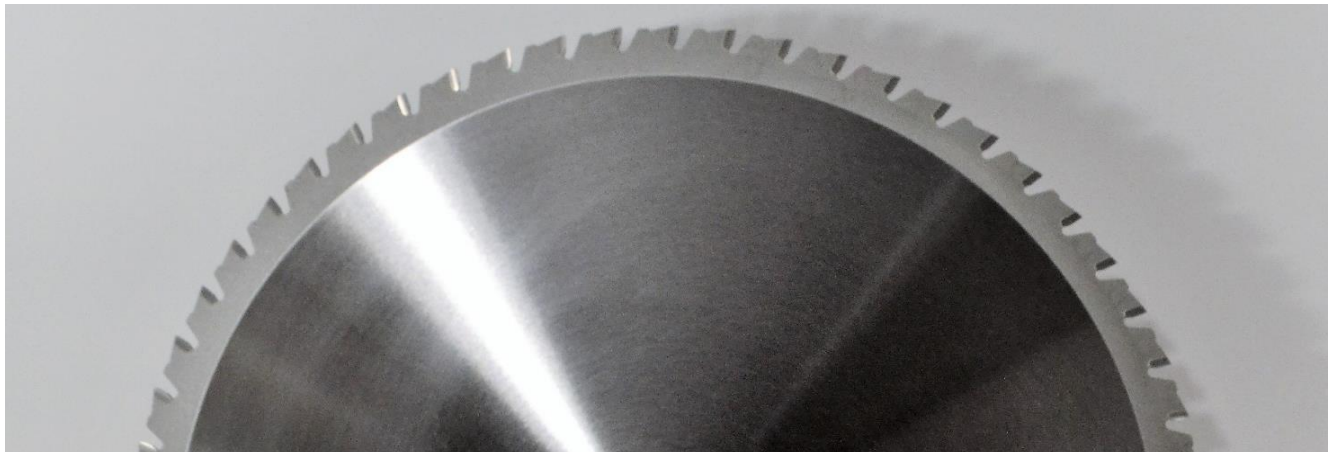

Abmessung	Nebenlöcher	Verzahnung	
305x2,2x25,4	keine	60	80
355x2,4x25,4	keine	80	90

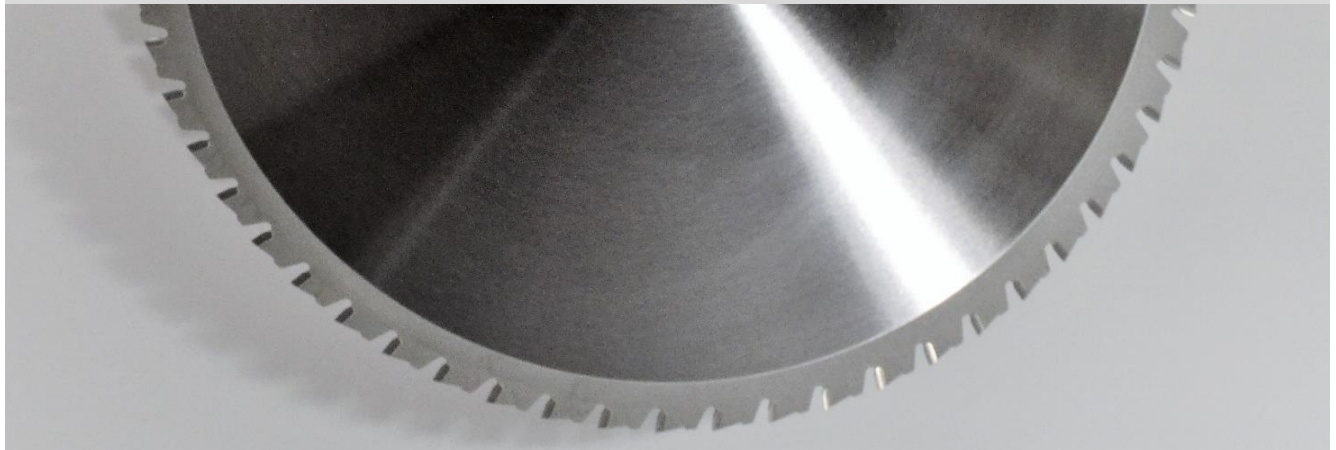

Metallbandsägeblätter Bimetall

M42

	Abmessung	Kombiverzahnung						
		2/3	3/4	4/6	5/8	6/10	8/12	10/14
🌿	1335 x 13 x 0,6						X	X
	1440 x 13 x 0,6						X	X
🌿	2450 x 27 x 0,9					X	X	X
	2480 x 27 x 0,9					X	X	
	2750 x 27 x 0,9			X	X	X		
🌿	2760 x 27 x 0,9				X	X	X	
🌿	2910 x 27 x 0,9		X	X				
	2945 x 27 x 0,9				X			
	2950 x 27 x 0,9			X	X	X		
	3320 x 27 x 0,9				X			
🌿	3350 x 27 x 0,9	X	X	X	X	X		
	3370 x 27 x 0,9				X	X		
	3660 x 27 x 0,9	X	X	X	X	X	X	X
🌿	3700 x 27 x 0,9			X				
	4200 x 34 x 1,1		X	X				
	4400 x 34 x 1,1			X				

Verpackungseinheit: 5 Stk. je Abmessung und Verzahnung

Individuelle Abmessungen realisieren wir gerne innerhalb einer Woche für Sie

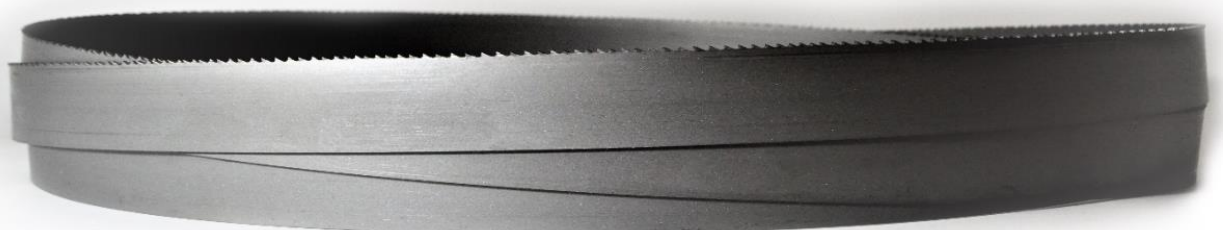

🌿 = Neu

Rohrkreissägeblätter

blank für Orbitalum / +GF+ & AxxAir

HSS-E Kobalt Co 5%

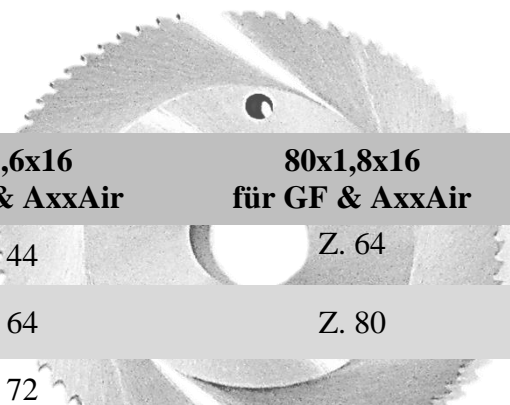

63x1,6x16 für GF	68x1,6x16 für GF & AxxAir	80x1,8x16 für GF & AxxAir	100x2,0x16 für GF
Z. 44	Z. 44	Z. 64	Z. 70
Z. 64	Z. 64	Z. 80	Sonderverzahnungen möglich
	Z. 72		
	Z. 84		

Black Fire beschichtet für Orbitalum / +GF+ & AxxAir

HSS-E Kobalt Co 5%

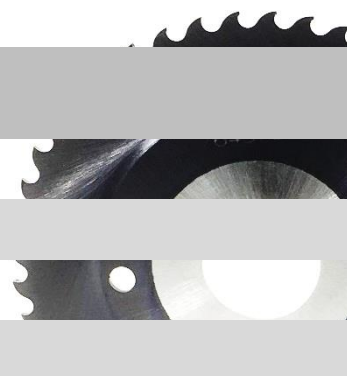

68x1,6x16 für GF & AxxAir	80x1,8x16 für GF & AxxAir
Z. 44	Z. 64
Z. 64	Z. 80
Z. 72	
Z. 84	

Black Fire ist eine Weiterentwicklung der Titanaluminiumnitrid (TiAlN) Beschichtung. Ausführlichere Informationen zu unseren Beschichtungen finden Sie [hier](#).



Segmentkreissägeblätter

HSS DMo5

Abmessung	Nebenlöcher	Zähne pro Segment					
		4	5	6	8	10	12
275x3,0x40	2/8,5/55+4/12/64		60 HZ	72 HZ	96* HZ	120 HZ	144* HZ
300x3,6x40	2/8,5/55+4/12/64				112 HZ	140 HZ	168 HZ
315x3,6x40	2/8,5/55+4/12/64		70 HZ	84 HZ	112 HZ	140 HZ	168 HZ
360x3,6x40	2/8,5/55+4/12/64		80 HZ	96 HZ	128 HZ	160 HZ	192 HZ
360x3,6x50	4/15/85+4/15/80	64 HZ	80 HZ	96 HZ	128 HZ	160 HZ	192 HZ
370x3,6x50	4/15/85+4/15/80	64 HZ	80 HZ	96 HZ	128 HZ	160 HZ	192 HZ
400x4,0x40	2/15/80+4/12/64		80 HZ	96 HZ	128 HZ	160 HZ	192 HZ
400x4,0x50	4/15/85+4/15/80	64 HZ	80 HZ	96* HZ	128* HZ	160 HZ	192 HZ
400x4,0x60	4/16/90+4/23/96			96 HZ	128 HZ		
425x4,0x40	2/15/80+4/12/64		90 HZ	108 HZ	144 HZ		
425x4,0x50	4/15/85+4/15/80	72 HZ	90 HZ	108 HZ	144 HZ	180 HZ	
450x4,0x50	4/15/80+4/18/100	72 HZ	90 HZ	108 HZ	144 HZ	180 HZ	
460x5,0x60	4/16/90+4/23/96	72 HZ	90 HZ	108 HZ	144 HZ		
630x6,0x80	4/22/120+4/27/160	80 HZ	100 HZ	120 HZ	160 HZ		
660x6,0x80	8/22/142	80 HZ	100 HZ	120 HZ	160 HZ		
710x6,2x80	4/22/120+4/27/160	96 HZ	120 HZ	144 HZ	192 HZ		
810x6,8x80	4/22/120+4/27/160		120 HZ	144 HZ			
910x7,0x80	4/22/120+4/27/160		150 HZ	180 HZ			
910x7,0x100	8/27/186		150 HZ	180 HZ	240 HZ		

***auch in HSS-E Kobalt ab Lager**



Vollstahlkreissägeblätter

HSS Vollstahlkreissägeblätter dampfbehandelt

HSS DMo5

Abmessung	Nebenlöcher	Zahnteilung													
		3mm	4mm	4,5mm	5mm	6mm	7mm	8mm	9mm	10mm	11mm	12mm	14mm	16mm	Ronde
200x1,8x32	2/8/45+2/11/63+4/9/50	200 BW	160 BW		128 HZ	100 HZ									0
210x2,0x32	2/8/45+2/11/63	210 BW	160 BW		140 HZ	120 HZ									0
225x2,0x32	2/8/45+2/11/63+4/9/50	220 BW	180 BW	160 BW	150 HZ	120 HZ		90 HZ							0
225x2,0x32	o.NL. für BS Praktika		180 BW			120 HZ									0
225x2,0x40	2/8/55+4/12/64	220 BW	180 BW		150 HZ	120 HZ		90 HZ							0
250x2,0x32	2/8/45+4/9/50+2/12/64	240 BW	200 BW		160 HZ	128 HZ		100 HZ		80 HZ					0
250x2,0x40	2/8/55+4/12/64	240 BW	200 BW		160 HZ	128 HZ		100 HZ		80 HZ					0
250x2,5x32	2/8/45+4/9/50+2/12/64		200 BW		160 HZ	128 HZ		100 HZ		80 HZ					0
250x2,5x40	2/8/55+4/12/64		200 BW		160 HZ	128 HZ		100 HZ		80 HZ					0
275x2,0x32	2/8/45+4/9/50+2/12/64	280 BW	220 BW		180 HZ	140 HZ		110 HZ							0
275x2,0x40	2/8/55+4/12/64	280 BW	220 BW		180 HZ	140 HZ		110 HZ							0
275x2,5x32	2/8/45+4/9/50+2/12/64	280 BW	220 BW		180 HZ	140 HZ		110 HZ							0
275x2,5x40	2/8/55+4/12/64	280 BW	220 BW		180 HZ	140 HZ	120 HZ	110 HZ	96 HZ	84 HZ		72 HZ			0
275x3,0x40	2/8/55+4/12/64		220 BW		180 HZ	140 HZ		110 HZ							0
300x2,5x32	2/8/45+4/9/50+2/12/64		240 BW	220 BW	200 HZ	160 HZ		120 HZ	100 HZ						0
300x2,5x40	2/8/55+4/12/64		240 BW	220 BW	200 HZ	160 HZ		120 HZ	100 HZ						0
300x3,0x40	2/8/55+4/12/64			220 BW		160 HZ		120 HZ							0
315x2,5x32	2/8/45+4/9/50+2/12/64		250 BW		220 HZ	200 HZ	160 HZ		120 HZ		100 HZ				0
315x2,5x40	2/8/55+4/12/64		250 BW		220 HZ	200 HZ	160 HZ		120 HZ		100 HZ				0
315x3,0x32	2/8/45+4/9/50+2/12/64					160 HZ									0
315x3,0x40	2/8/55+4/12/64		250 BW		220 HZ	200 HZ	160 HZ		120 HZ		100 HZ		80 HZ		0
315x3,0x50	4/15/80+4/14/85														0
325x3,0x40	2/8/55+4/12/64				220 HZ	160 HZ		120 HZ							0
350x2,5x32	2/8/45+4/12/64+2/12/75		280 BW		220 HZ	180 HZ		140 HZ							0
350x2,5x40	2/8/55+4/12/64				220 HZ	180 HZ		140 HZ							0
350x2,5x50	4/15/80+4/14/85				220 HZ		160 HZ		120 HZ						0
350x3,0x32	2/8/45+4/12/64+2/12/75		280 BW		220 HZ	180 HZ		140 HZ		110 HZ					0
350x3,0x40	2/8/55+4/12/64		280 BW		220 HZ	180 HZ	160 HZ	140 HZ	120 HZ	110 HZ		90 HZ	80 HZ	70 HZ	0

Unverzahnte Kreissägeblätter abzüglich 8 % Rabatt. Sonderverzahnungen gegen 10 € Aufpreis bis Ø 370mm.
Ab Ø 400 mm erhalten Sie jede gewünschte Verzahnung kurzfristig ohne Aufpreis.

Vollstahlkreissägeblätter dampfbehandelt

HSS DMo5

Abmessung	Nebenlöcher	Zahnteilung											
		5mm	6mm	7mm	8mm	9mm	10mm	11mm	12mm	14mm	16mm	18mm	Ronde
350x3,0x50	4/15/80+4/14/85	220 HZ		160 HZ		120 HZ		100 HZ		80 HZ			0
360x3,5x50	4/15/80+4/14/85												0
370x3,0x32	2/8/45+4/12/64+2/12/75												0
370x3,0x40	2/15/80+4/12/64+2/9/55	220 HZ	200 HZ	160 HZ	140 HZ		120 HZ		100 HZ	80 HZ			0
370x3,0x50	4/15/80+4/14/85	220 HZ		160 HZ			120 HZ		100 HZ	80 HZ			0
400x3,0x40	2/15/80+4/12/64+2/15/100		200 HZ		160 HZ		128 HZ						0
400x3,0x50	4/15/80+4/14/85		220 HZ	180 HZ	160 HZ	140 HZ			100 HZ				0
400x3,5x40	2/15/80+4/12/64+2/15/100		200 HZ		160 HZ		128 HZ						0
400x3,5x50	4/15/80+4/14/85			180 HZ		140 HZ			100 HZ				0
400x4,0x40	2/15/80+4/12/64+2/15/100												0
400x4,0x50	4/15/80+4/14/85						128 HZ			96 HZ	80 HZ		0
425x3,5x40	2/15/80+4/12/64+2/15/100												0
425x3,5x50	4/15/80+4/14/85												0
425x4,0x40	2/15/80+4/12/64+2/15/100												0
425x4,0x50	4/15/80+4/14/85									96 HZ		76 HZ	0
450x3,5x40	2/15/80+4/12/64+2/15/100												0
450x3,5x50	4/15/80+4/18/100												0
450x4,0x40	2/15/80+4/12/64+2/15/100		240 HZ		180 HZ		140 HZ		120 HZ	100 HZ	90 HZ		0
450x4,0x50	4/15/80+4/18/100												0
470x4,0x40	2/15/80+4/12/64+2/15/100												0
500x4,0x40	2/15/80+4/12/64+2/15/100												0

Unverzahnte Kreissägeblätter abzüglich 8 % Rabatt. Sonderverzahnungen gegen 10 € Aufpreis bis Ø 370mm.
Ab Ø 400 mm erhalten Sie jede gewünschte Verzahnung kurzfristig ohne Aufpreis.

HSS Vollstahlkreissägeblätter blank

HSS DMo5

Abmessung	Nebenlöcher
-----------	-------------

225x2,0x32	2/8/45+2/11/63+4/9/50
250x2,0x32	2/8/45+4/9/50+2/12/64
250x2,0x40	2/8/55+4/12/64
250x2,5x32	2/8/45+4/9/50+2/12/64
275x2,0x32	2/8/45+4/9/50+2/12/64
275x2,0x40	2/8/55+4/12/64
275x2,5x32	2/8/45+4/9/50+2/12/64
275x2,5x40	2/8/55+4/12/64
300x2,5x32	2/8/45+4/9/50+2/12/64
300x2,5x40	2/8/55+4/12/64
315x2,0x32	2/8/45+4/9/50+2/12/64
315x2,0x40	2/8/55+4/12/64
315x2,5x32	2/8/45+4/9/50+2/12/64
315x2,5x40	2/8/55+4/12/64
315x3,0x40	2/8/55+4/12/64
350x2,5x32	2/8/45+4/12/64+2/12/75
350x2,5x40	2/8/55+4/12/64
350x3,0x32	2/8/45+4/12/64+2/12/75
350x3,0x40	2/8/55+4/12/64
350x3,0x50	4/15/80+4/14/85

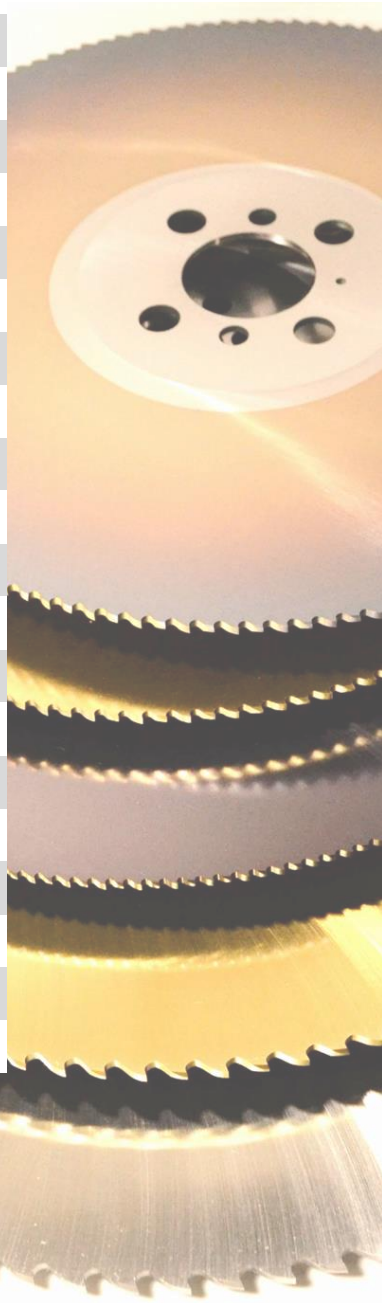

Abmessung	Nebenlöcher
-----------	-------------

370x3,0x40	2/15/80+4/12/64+2/9/55
370x3,0x50	4/15/80+4/14/85
400x3,0x40	2/15/80+4/12/64+2/15/100
400x3,0x50	4/15/80+4/14/85
400x3,5x40	2/15/80+4/12/64+2/15/100
400x3,5x50	4/15/80+4/14/85
400x4,0x50	4/15/80+4/14/85
425x3,0x50	4/15/80+4/14/85
425x3,5x40	2/15/80+4/12/64+2/15/100
425x3,5x50	4/15/80+4/14/85
425x4,0x50	4/15/80+4/14/85
450x3,0x40	2/15/80+4/12/64+2/15/100
450x3,0x50	4/15/80+4/18/100
450x3,5x40	2/15/80+4/12/64+2/15/100
450x3,5x50	4/15/80+4/18/100
450x4,0x40	2/15/80+4/12/64+2/15/100
450x4,0x50	4/15/80+4/18/100

*Wir halten unverzahnte blanke Sägeblätter vor,
die wir gerne kurzfristig Ihren persönlichen Anforderungen entsprechend
verzahnen und beschichten.*

 = Neu

HSS Vollstahlkreissägeblätter blank für Baiermaschinen

HSS DMo5 blank

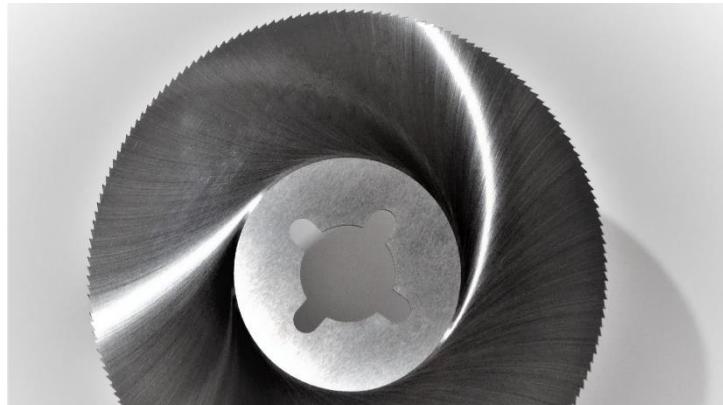

Abmessung	Nebenlöcher	Verzahnung		Ronde
175x2,0x32	4 Keilnuten	180 AW	220 AW	Z. 0
250x2,0x32	4 Keilnuten	250 AW	320 AW	Z. 0

HSS Vollstahlkreissägeblätter dampfbehandelt für Rems Roller

HSS DMo5

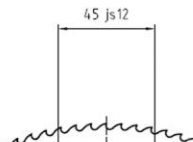

Abmessung	Nebenlöcher	Verzahnung	
225x2,0x32	1/9/45 + 1/9,8/45	120 HZ	220 BW

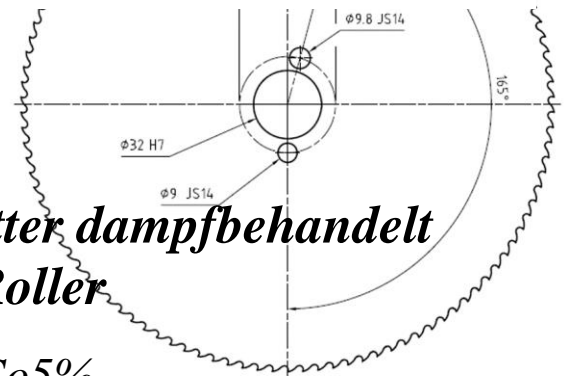

HSS-E Vollstahlkreissägeblätter dampfbehandelt für Rems Roller

HSS-E Kobalt Co5%

Abmessung	Nebenlöcher	Verzahnung	
225x2,0x32	1/9/45 + 1/9,8/45	220 BW	

HSS-E Vollstahlkreissägeblätter dampfbehandelt

Kobalt Co 5%

Abmessung	Nebenlöcher	Zahnteilung							
		3mm	4mm	4,5mm	5mm	6mm	7mm	8mm	Ronde
225x2,0x32	2/8/45+2/11/63+4/9/50	220 BW	180 BW			120 HZ			0
225x2,0x40	2/8/55+4/12/64	220 BW	180 BW			120 HZ			0
250x2,0x32	2/8/45+4/9/50+2/12/64		200 BW		160 HZ	128 HZ			0
250x2,0x40	2/8/55+4/12/64		200 BW		160 HZ	128 HZ			0
250x2,5x32	2/8/45+4/9/50+2/12/64								0
250x2,5x40	2/8/55+4/12/64								0
275x2,0x32	2/8/45+4/9/50+2/12/64								0
275x2,0x40	2/8/55+4/12/64		220 BW						0
275x2,5x32	2/8/45+4/9/50+2/12/64		220 BW		180 HZ	140 HZ		110 HZ	0
275x2,5x40	2/8/55+4/12/64	280 BW	220 BW		180 HZ	140 HZ		110 HZ	0
300x2,5x32	2/8/45+4/9/50+2/12/64		240 BW	220 BW		160 HZ		120 HZ	0
300x2,5x40	2/8/55+4/12/64			220 BW		160 HZ		120 HZ	0
315x2,5x32	2/8/45+4/9/50+2/12/64			220 HZ		160 HZ		120 HZ	0
315x2,5x40	2/8/55+4/12/64			220 HZ		160 HZ		120 HZ	0
315x3,0x40	2/8/55+4/12/64			220 HZ		160 HZ		120 HZ	0

*Unverzahnte Kreissägeblätter abzüglich 8 % Rabatt. Sonderverzahnungen gegen 10 € Aufpreis bis Ø 370mm.
Ab Ø 400 mm erhalten Sie jede gewünschte Verzahnung kurzfristig ohne Aufpreis.*

HSS-E Vollstahlkreissägeblätter dampfbehandelt

Kobalt Co 5%

Abmessung	Nebenlöcher	Zahnteilung							Ronde
		4mm	5mm	6mm	7mm	8mm	9mm	10mm	
350x3,0x32	2/8/45+4/12/64+2/12/75	280 BW	220 HZ	180 HZ		140 HZ		110 HZ	0
350x2,5x40	2/8/55+4/12/64								0
350x3,0x40	2/8/55+4/12/64	280 BW	220 HZ	180 HZ		140 HZ		110 HZ	0
350x3,0x50	4/15/80+4/14/85		220 HZ		160 HZ				0
370x3,0x32	2/8/45+4/12/64+2/12/75								0
370x3,0x40	2/15/80+4/12/64+2/9/55		220 HZ	200 HZ	160 HZ	140 HZ		120 HZ	0
370x3,0x50	4/15/80+4/14/85		220 HZ		160 HZ			120 HZ	0
400x3,0x40	2/15/80+4/12/64+2/15/100								0
400x3,0x50	4/15/80+4/14/85								0
400x3,5x40	2/15/80+4/12/64+2/15/100								0
400x3,5x50	4/15/80+4/14/85								0
400x4,0x50	4/15/80+4/14/85								0
425x3,5x40	2/15/80+4/12/64+2/15/100								0
425x3,5x50	4/15/80+4/14/85								0
450x4,0x40	2/15/80+4/12/64+2/15/100								0
450x4,0x50	4/15/80+4/18/100								0

*Unverzahnte Kreissägeblätter abzüglich 8 % Rabatt. Sonderverzahnungen gegen 10 € Aufpreis bis Ø 370mm.
Ab Ø 400 mm erhalten Sie jede gewünschte Verzahnung kurzfristig ohne Aufpreis.*